

MATRIX

S7xi

S7xe

S5x

S3x





3	IMPORTANT PRECAUTIONS
5	ASSEMBLY
9	BEFORE YOU BEGIN
11	MAINTENANCE
11	PRODUCT SPECIFICATIONS

IMPORTANT PRECAUTIONS



SAVE THESE INSTRUCTIONS

- When using a Stepper, basic precautions should always be followed, including the following: Read all instructions before using this equipment. It is the responsibility of the owner to ensure that all users of this equipment are adequately informed of all warnings and precautions.
- This equipment is intended for commercial use. To ensure your safety and protect the equipment, read all instructions before operating.

DANGER!

TO REDUCE THE RISK OF ELECTRICAL SHOCK:

- Always unplug the equipment from the electrical outlet immediately after using, before cleaning, performing maintenance and putting on or taking off parts.

WARNING!

TO REDUCE THE RISK OF BURNS, FIRE, ELECTRICAL SHOCK OR INJURY TO PERSONS:

- An appliance should never be left unattended when plugged in. Unplug the entertainment equipment from outlet when not in use and before putting on or taking off parts.
- This product must be used for its intended purpose described in this Owner's Manual.
- This unit should not be used by persons weighing more than specified in the OWNER'S MANUAL SPECIFICATIONS SECTION. Failure to comply will void the warranty.
- To prevent electrical shock, never drop or insert any object into any opening.
- Do not remove side covers. Service should only be done by an authorized service technician.
- Never operate the Stepper with the air opening blocked. Keep the air opening clean, free, of lint, hair and the like.
- Never operate the product if it has a damaged cord or plug, if it is not working properly, if it has been damaged, or immersed in water. Return the unit to a service center for examination and repair.
- Do not carry this unit by entertainment equipment power cord or use cord as handle.
- Keep any of the entertainment equipment power cords away from heated surfaces
- Keep hands and loose clothing away from moving parts.
- Close supervision is necessary when the Stepper is used by or near children or disabled persons.
- Do not use outdoors.
- Do not operate where aerosol (spray) products are being used or where oxygen is being administered.
- Connect this Stepper to a properly grounded outlet only.
- To disconnect, turn all entertainment controls to the off position, then remove plug from outlet.
- Keep power cord away from heated surfaces. Do not carry this unit by its supply cord or use the cord as a handle.
- Do not use other attachments that are not recommended by the manufacturer. Attachments may cause injury.
- Disconnect all power before servicing or moving the equipment. To clean, wipe surfaces down with soap and slightly damp cloth only; never use solvents. (See MAINTENANCE)
- The unit should never be left unattended when plugged in. Unplug from outlet when not in use, and before putting on or taking off parts.
- Do not operate under blanket or pillow. Excessive heating can occur and cause fire, electric shock, or injury to persons.
- At NO time should pets or children under the age of 14 be closer to the unit than 10 feet.
- At NO time should children under the age of 14 use the unit.
- Incorrect or excessive exercise may cause injury. If you experience any kind of pain, including but not limited to chest pains, nausea, dizziness, or shortness of breath, stop exercising immediately and consult your physician before continuing.
- Do not wear clothes that might catch on any part of the unit.
- Always wear athletic shoes while using this equipment.
- Do not jump on the unit.
- At no time should more than one person be on unit while in operation.
- Children over the age of 14 or disabled persons should not use the unit without adult supervision.
- Never operate the unit if it has a damaged cord or plug, if it is not working properly, if it has been dropped or damaged, or immersed in water. Return the unit to a service center for examination and repair.
- To disconnect, turn all controls to the off position, then remove plug from outlet.
- Do not remove the console covers unless instructed by Customer Tech Support. Service should only be done by an authorized service technician.
- This unit is not equipped with a free wheel. Pedal speed should be reduced in a controlled manner.
- Heart rate monitoring systems may be inaccurate.
- Over exercising may result in serious injury or death.
- If you feel faint, stop exercising immediately.

CAUTION!

CONSULT A PHYSICIAN BEFORE USING THIS EQUIPMENT. READ OWNER'S MANUAL BEFORE USE.

- It is essential that this equipment is used only indoors, in a climate controlled room. If this equipment has been exposed to colder temperatures or high moisture climates, it is strongly recommended that the equipment is warmed up to room temperature before first time use.



POWER REQUIREMENTS

DEDICATED CIRCUIT AND ELECTRICAL INFO

A "Dedicated Circuit" means that each outlet you plug into should not have anything else running on that same circuit. The easiest way to verify this is to locate the main circuit breaker box, and turn off the breaker(s) one at a time. Once a breaker has been turned off, the only thing that should not have power to it are the units in question. No lamps, vending machines, fans, sound systems, or any other item should lose power when you perform this test.

Non-looped (isolated) neutral/grounding means that each circuit must have an individual neutral/ground connection coming from it, and terminating at an approved earth ground. You cannot "jumper" a single neutral/ground from one circuit to the next.

ELECTRICAL REQUIREMENTS

For your safety and to ensure good unit performance, the ground on this circuit must be non-looped (isolated). Please refer to NEC article 210-21 and 210-23. Any alterations to the standard power cord provided could void all warranties of this product.

The S3x, S5x and S7xe are designed to be self powered and do not require an external power supply source to operate. Without an external power supply, the console's start-up time may be delayed. Add-on TV's and other console accessories will increase the time needed for start-up. An external power supply will ensure power is provided to the console at all times and is recommended when add-on accessories are used.

For units with an integrated TV (like the 7xe and 7xi), the TV power requirements are included in the unit. An RG6 coaxial cable with 'F Type' compression fittings on each end will need to be connected to the cardio unit and the video source. Additional power requirements are not needed for the add-on digital TV (3x and 5x). For units with an add-on PCTV (3x and 5x), the TV power requirements are separate.

NOTE: ALL UNITS WITH VIRTUAL ACTIVE™ MUST BE POWERED!

110 V UNITS

All Matrix 3x, 5x, 7xe and 7xi 110 V Steppers require the use of a 100-125 V, 60 Hz and a 15 A "Dedicated Circuit", with a non-looped (isolated) neutral/ground for power. This outlet should be a NEMA 5-15R and have the same configuration as the plug. No adapter should be used with this product. Steppers can be daisy-chained together with up to 4 units per 15 A dedicated circuit. Matrix daisy-chain cord adapters are sold separately.

220 V UNITS

All Matrix 3x, 5x, 7xe and 7xi 220 V Steppers require the use of a 216-250 V, 50 Hz and a 15 A "Dedicated Circuit", with a non-looped (isolated) neutral/ground for power. This outlet should be a NEMA 6-15R and have the same configuration as the plug. No adapter should be used with this product. These Steppers can be daisy-chained together with up to 4 units per dedicated 15 A circuit. Matrix daisy-chain cord adapters are sold separately.

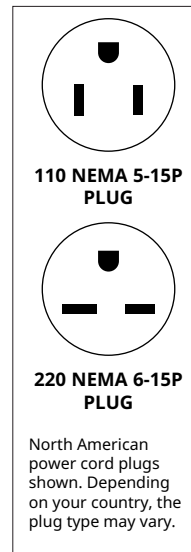

GROUNDING INSTRUCTIONS

The unit must be grounded. If it should malfunction or breakdown, grounding provides a path of least resistance for electric current to reduce the risk of electric shock. The unit is equipped with a cord having an equipment-grounding conductor and a grounding plug. The plug must be plugged into an appropriate outlet that is properly installed and grounded in accordance with all local codes and ordinances. If the user does not follow these grounding instructions, the user could void the Matrix limited warranty.

ADDITIONAL ELECTRICAL INFO

In addition to the dedicated circuit requirement, the proper gauge wire must be used from the circuit breaker box, to each outlet that will have the maximum number of units running off of it. If the distance from the circuit breaker box to each outlet, is 100 ft (30.5 m) or less, then 12 gauge wire should be used. For distances greater than 100 ft (30.5 m) from the circuit breaker box to the outlet, a 10 gauge wire should be used.

ENERGY SAVING / LOW-POWER MODE

All units are configured with the ability to enter into an energy saving / low-power mode when the unit has not been in use for a specified period of time. Additional time may be required to fully reactivate this unit once it has entered the low-power mode. This energy saving feature may be enabled or disabled from within the 'Manager Mode' or 'Engineering Mode.'

ADD-ON PCTV (3X AND 5X)

A 15 A or 20 A "Dedicated Circuit" with a non-looped (isolated) neutral/ground is required. Each PCTV requires at least 1.2 A of current. No more than 12 PCTVs should be used for each 15 A circuit and no more than 16 PCTVs should be used for each 20 A circuit. The power outlet should have the same configuration as the plug. No adapter should be used with this product. An RG6 coaxial cable with 'F Type' compression fittings will need to be connected between the video source and each add-on PCTV unit.

ADD-ON DIGITAL TV (3X AND 5X)

Additional power requirements are not needed for the add-on digital TV. An RG6 coaxial cable with 'F Type' compression fittings will need to be connected between the video source and each add-on digital TV unit.

BATTERY CHARGE (3X, 5X ONLY)

The Stepper saves its battery charge by moving into a shutdown mode whenever **STEP FASTER** appears on the display. If the user does not maintain a step rate above 35 steps per minute, then a 30-second shutdown process begins.

When the battery voltage is low, **LOW BATTERY** appears on the display if the unit is moving into the shutdown mode. The following situation is the time to recharge the battery:

- If no one has used the unit for an extended period of time, the battery may need recharging.
- The unit continues to function with a low battery; however, user and program information is lost once the user stops.

If the battery must be recharged, use the optional power adapter charging unit. The charger should be connected to the Stepper for a minimum of eight hours to ensure a thorough charge. After a completion of charge, the battery light turns from red into green (see illustration). If **LOW BATTERY** still appears on the display after a full charge, the battery could be extinct. Please check with an authorized service technician for replacing the battery.

CAUTION: The battery stored inside the unit contains hazardous materials to the environment. Proper disposal of the battery is required by the local law.

WARNING!

- Connect this exercise product to a properly grounded outlet only.
- Never operate product with a damaged cord or plug even if it is working properly. Never operate any product if it appears damaged, or has been immersed in water. Contact Customer Tech Support for replacement or repair.

Failure to follow these specifications can cause damage to your product and can void the warranty:

- All video and power outlets must be functional the day of delivery / assembly of the product. The client is responsible for any additional installation charges associated with return visits.
- Electrical supply may fluctuate in your area. To ensure stable performance of the product, use the proper gauge wire.

DANGER!

Improper connection of the equipment-grounding conductor can result in a risk of electric shock. Check with a qualified electrician or serviceman if you are in doubt as to whether the product is properly grounded. Do not modify the plug provided with the product. If it will not fit the outlet, have a proper outlet installed by a qualified electrician.





ASSEMBLY

UNPACKING

Unpack the equipment where you will be using it. Place the carton on a level flat surface. It is recommended that you place a protective covering on your floor. Never open box when it is on its side.

IMPORTANT NOTES

During each assembly step, ensure that ALL nuts and bolts are in place and partially threaded.

Several parts have been pre-lubricated to aid in assembly and usage. Please do not wipe this off. If you have difficulty, a light application of lithium grease is recommended.

WARNING!

There are several areas during the assembly process that special attention must be paid. It is very important to follow the assembly instructions correctly and to make sure all parts are firmly tightened. If the assembly instructions are not followed correctly, the equipment could have parts that are not tightened and will seem loose and may cause irritating noises. To prevent damage to the equipment, the assembly instructions must be reviewed and corrective actions should be taken.

NEED HELP?

If you have questions or if there are any missing parts, contact Customer Tech Support. Contact information is located on the information card.

TOOLS REQUIRED:

- 6mm Allen Wrench
- 5mm Allen Wrench
- Phillips Screwdriver

PARTS INCLUDED:

- 1 Main Frame
- 1 Stabilizer Tube
- 1 Stabilizer Tube Cover
- 1 Console Mast
- 1 Console Mast Bracket
- 2 Upper Handlebars
- 2 Lower Handlebars
- 1 Pulse Grip Handlebar
- 1 Handlebar Joint Connector
- 1 Bottle Holder
- 1 Power Cord
- 1 Hardware Kit

Console sold separately

1

Black & Red Hardware Bags

Description	Qty
A Bolt (40 mm)	4
B Lock Washer	4
C Bolt (15 mm)	4

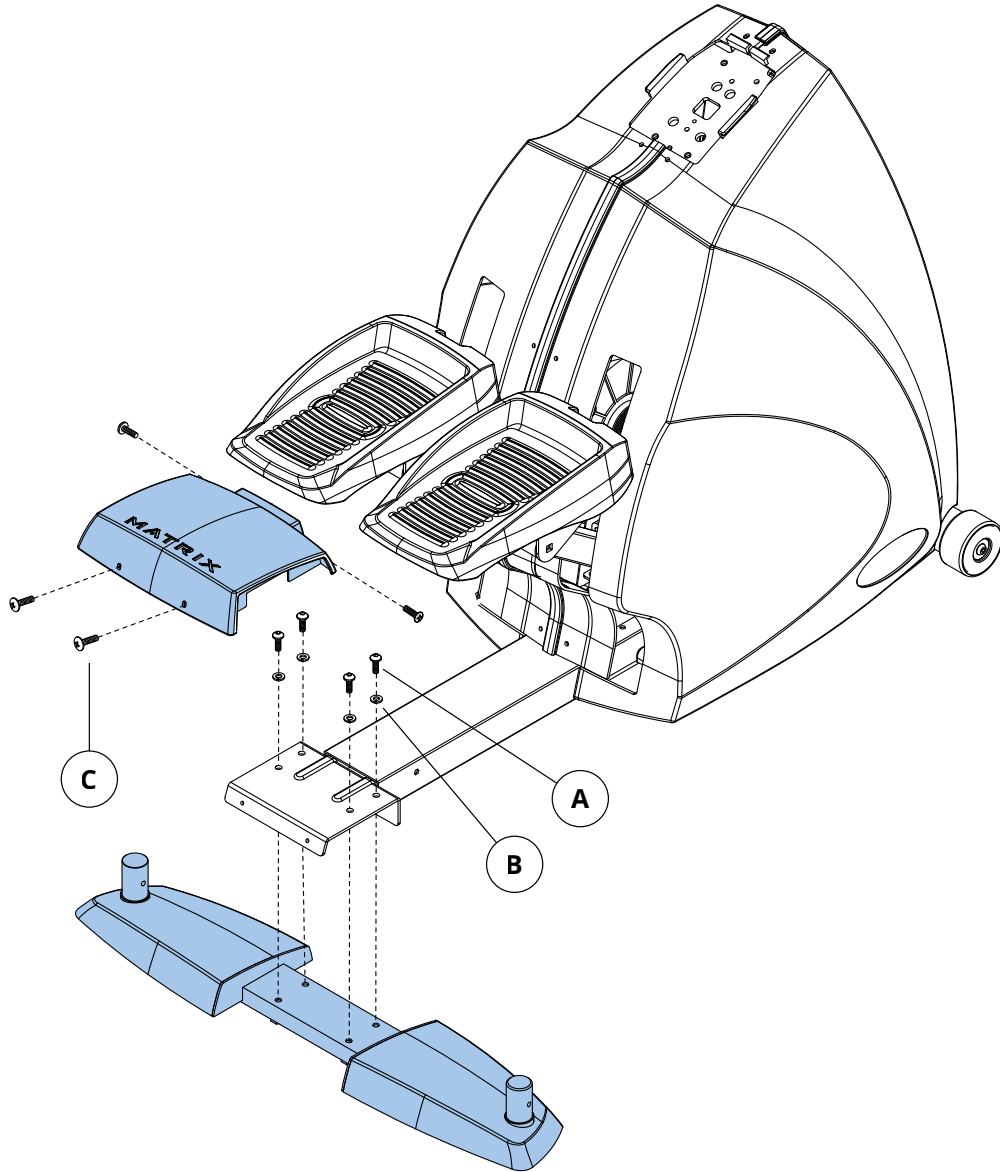

2

White Hardware Bags

Description	Qty
D Bolt	8
E Lock Washer	8

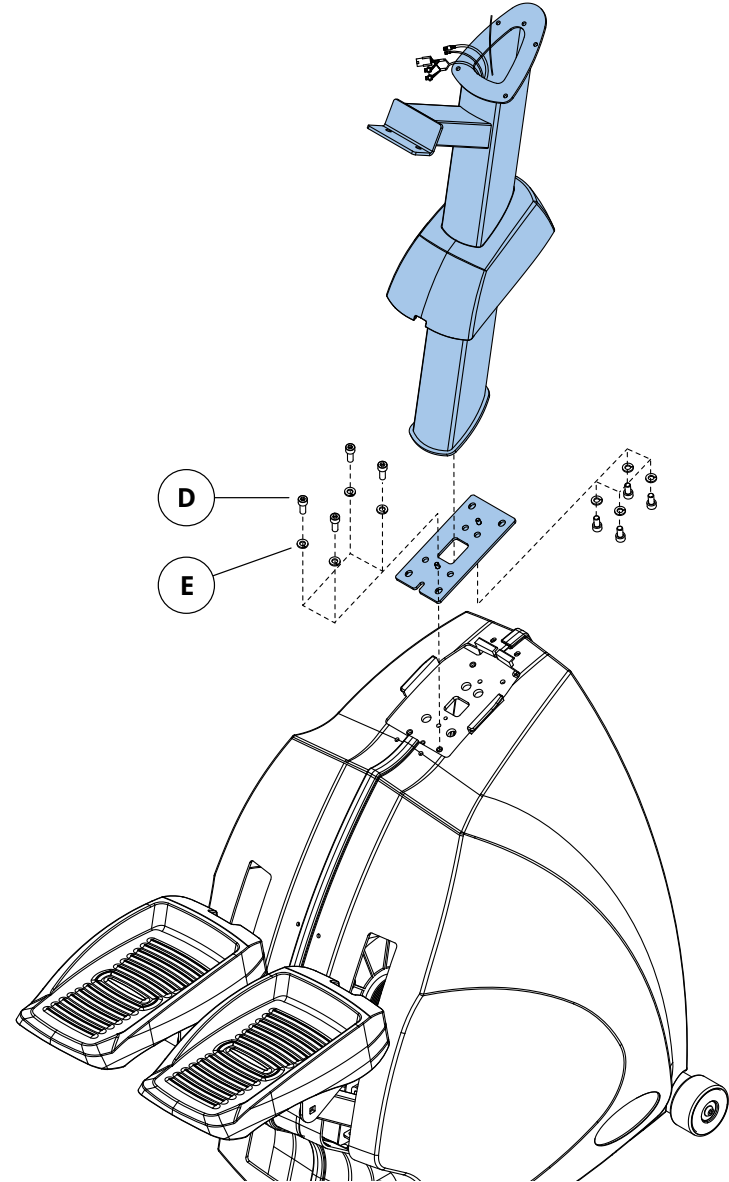

**3****Orange Hardware Bag**

Description	Qty
F Bolt Set	2
G Arc Washer	8
H Bolt (16m)	4

Yellow Hardware Bag

Description	Qty
I Bolt (45 mm)	2
J Lock Washer	2

Green Hardware Bag

Description	Qty
K Bolt (16 mm)	3
L Lock Washer	3

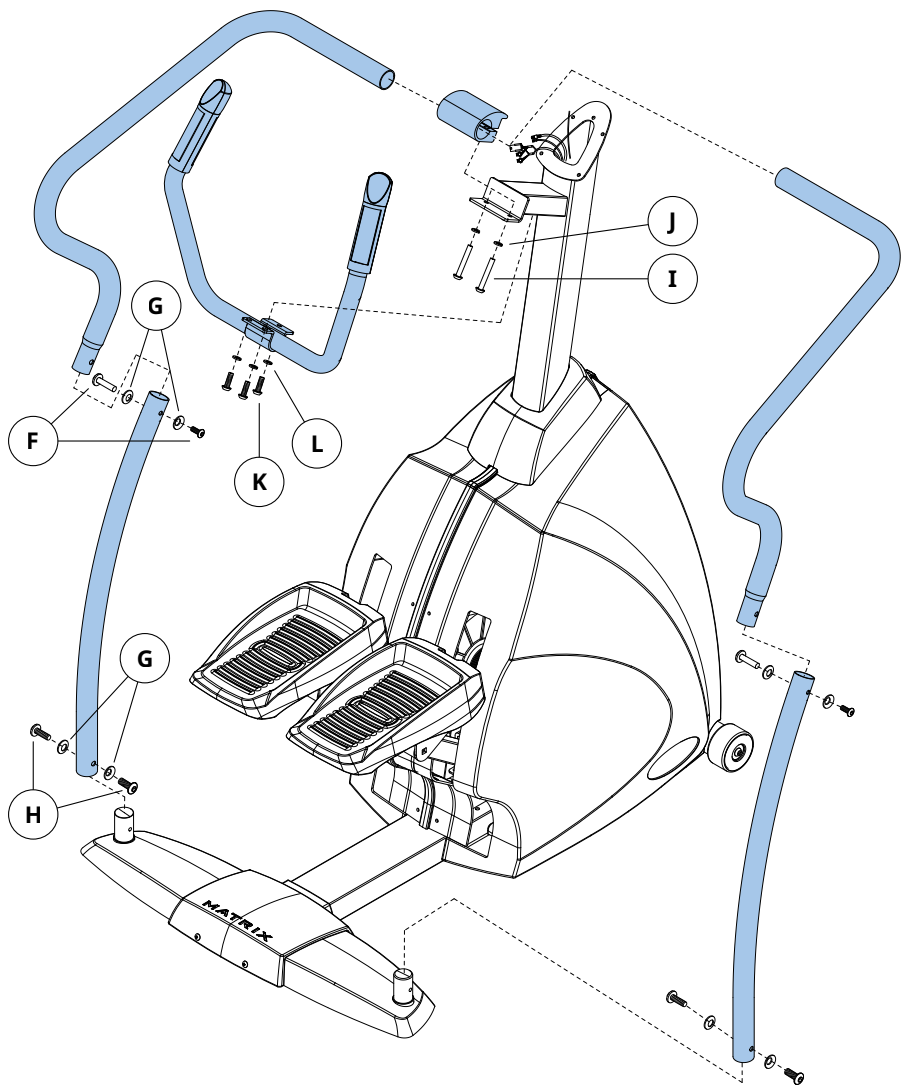
**4****Pre-installed Hardware**

Description	Qty
M Screw	4

Blue Hardware Bag

Description	Qty
N Bolt	2

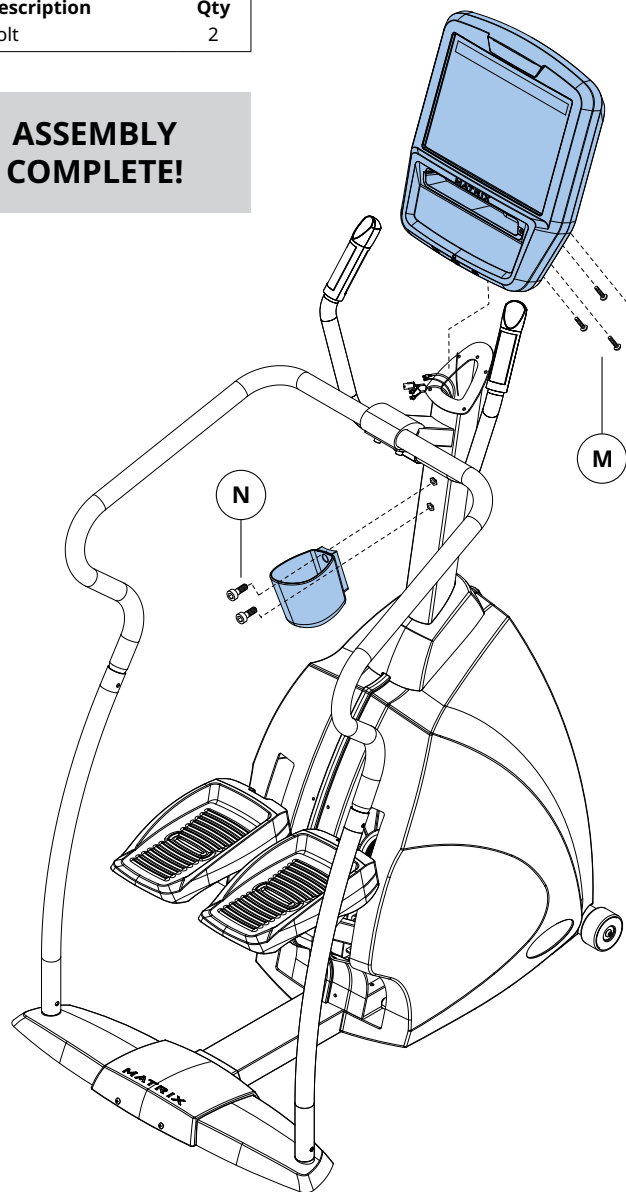
ASSEMBLY COMPLETE!

BEFORE YOU BEGIN

LOCATION OF THE UNIT

Place the unit on a level and stable surface away from direct sunlight. The intense UV light can cause discoloration on the plastics. Locate your unit in an area with cool temperatures and low humidity. Please leave a clear zone behind the unit that is at least 24" (600 mm). This zone must be clear of any obstruction and provide the user a clear exit path from the machine. Do not place the unit in any area that will block any vent or air openings. The unit should not be located in a garage, covered patio, near water or outdoors.

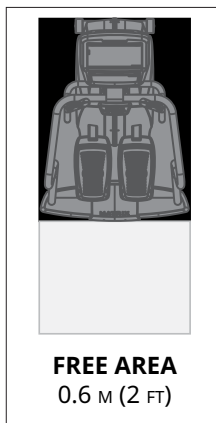

LEVELING THE EQUIPMENT

Locate a level, stable surface to position the Stepper. The Stepper has leveling feet located under the foot support. If your Stepper wobbles in the location where you intended to use it, loosen the lock nut on the adjusting foot and adjust the feet until stable. Once level, lock the adjusting feet by tightening the lock nut to the frame.

WARNING!

Our equipment is heavy, use care and additional help if necessary when moving. Failure to follow these instructions could result in injury.

POWER

If your unit is powered by a power supply, the power must be plugged into the power jack, which is located in the front of the machine near the stabilizer tube. Some units have a power switch, located next to the power jack. Make sure it is in the on position. Unplug cord when not in use.

WARNING!

Never operate equipment if it has a damaged cord or plug, if it is not working properly, if it has been damaged, or immersed in water. Contact Customer Tech Support for examination and repair.

PROPER USAGE

MOUNTING THE STEPPER

1. Stand behind the unit.
2. While holding both of the rear arm handles, place one foot on the corresponding footpad. Wait until the footpad comes to a stop at the bottom of the stroke.
3. Then place your other foot on the opposite pedal.
4. Your unit offers a variety of foot positions. Moving your foot to the forward most position of the foot pad increases your step height, which will create a feel similar to a step machine. Placing your foot toward the back of the foot pad decreases your step height and creates more of a gliding feel, similar to a smooth walk or run. Always make sure your entire foot is secured on the foot pad. The pedal motion is dependent.
5. To determine proper workout position, stand on the pedal with your foot on the center of the pedal. Keep your knees slightly bent at all times.

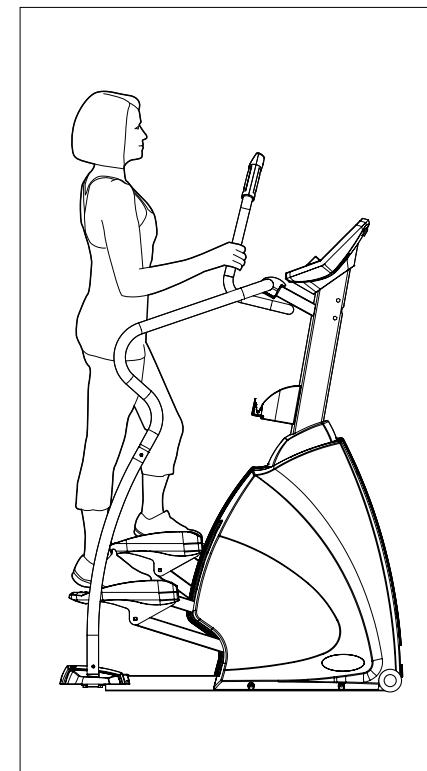



USING THE HEART RATE FUNCTION

The heart rate function on this product is not a medical device. While heart rate grips can provide a relative estimation of your actual heart rate, they should not be relied on when accurate readings are necessary. Some people, including those in a cardiac rehab program, may benefit from using an alternate heart rate monitoring system like a chest or wrist strap. Various factors, including movement of the user, may affect the accuracy of your heart rate reading. The heart rate reading is intended only as an exercise aid in determining heart rate trends in general. Please consult your physician.

PULSE GRIPS

Place the palm of your hands directly on the grip pulse handlebars. Both hands must grip the bars for your heart rate to register. It takes 5 consecutive heart beats (15-20 seconds) for your heart rate to register. When gripping the pulse handlebars, do not grip tightly. Holding the grips tightly may elevate your blood pressure. Keep a loose, cupping hold. You may experience an erratic readout if consistently holding the grip pulse handlebars. Make sure to clean the pulse sensors to ensure proper contact can be maintained.

WIRELESS HEART RATE RECEIVER

When used in conjunction with a **wireless chest transmitter**, your heart rate can be transmitted wirelessly to the unit and displayed on the console.

Prior to wearing the wireless chest transmitter on your chest, moisten the two rubber electrodes with water. Center the chest strap just below the breast or pectoral muscles, directly over your sternum, with the logo facing out. NOTE: The chest strap must be tight and properly placed to receive an accurate and consistent readout. If the chest strap is too loose, or positioned improperly, you may receive an erratic or inconsistent heart rate readout.

WARNING!

Heart rate monitoring systems may be inaccurate. Over exercising may result in serious injury or death. If you feel faint, stop exercising immediately.

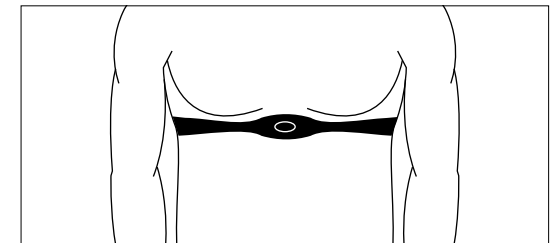
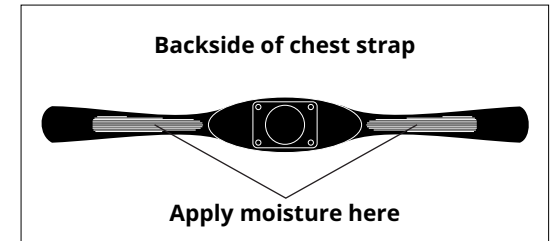

MAINTENANCE

1. Any and all part removal or replacement must be performed by a qualified service technician.
2. DO NOT use any equipment that is damaged and or has worn or broken parts. Use only replacement parts supplied by your country's local MATRIX dealer.
3. MAINTAIN LABELS AND NAMEPLATES: Do not remove labels for any reason. They contain important information. If unreadable or missing, contact your MATRIX dealer for a replacement.
4. MAINTAIN ALL EQUIPMENT: Preventative maintenance is the key to smooth operating equipment as well as keeping your liability to a minimum. Equipment needs to be inspected at regular intervals.
5. Ensure that any person(s) making adjustments or performing maintenance or repair of any kind is qualified to do so. MATRIX dealers will provide service and maintenance training at our corporate facility upon request.

WARNING

To remove power from the Stepper, the power cord must be disconnected from the wall outlet.

PRODUCT SPECIFICATIONS

	S7xi Stepper	S7xe Stepper	S5x Stepper	S3x Stepper
Max User Weight	182 kg / 400 lbs			
Product Weight	117.7 kg / 259 lbs	117.7 kg / 259 lbs	116 kg / 255 lbs	117.2 kg / 258 lbs
Shipping Weight	125.5 kg / 276 lbs	125.5 kg / 276 lbs	123.6 kg / 272 lbs	124.5 kg / 274 lbs
Overall Dimensions (L x W x H)*	114.3 x 78.7 x 179.1 cm / 45" x 31" x 70.5"			

* Ensure a minimum clearance width of 0.6 meters (24") for access to and passage around MATRIX equipment. Please note, 0.91 meters (36") is the ADA recommended clearance width for individuals in wheelchairs.

MAINTENANCE SCHEDULE

ACTION	FREQUENCY
Unplug the unit. Clean entire machine using water and a mild soap or other Matrix approved solution (cleaning agents should be alcohol and ammonia free).	DAILY
Check all connecting joint areas for tightness of bolt assemblies.	QUARTERLY
For 7xe consoles, enter service mode and select 'test'. Select 'touch calibration' and then select 'start'. Follow the on-screen prompts and touch the screen where indicated.	QUARTERLY



MATRIX